

Low-Voltage/Low-Power Solutions

INDUSTRY'S LOWEST VOLTAGE MCUs



COMPETITION ECLIPSED

WWW.SILABS.COM/POINT9

DESCRIPTION

The C8051F9xx product family is the industry's first MCU family capable of operating down to 0.9 V and up to 3.6 V, enabling single-cell battery operation as well as dramatically increasing battery life for dual-cell applications. With an integrated dc-dc converter, the C8051F9xx has been designed to provide a fast wake-up time, low active-mode, and ultra-low sleep mode current consumptions. The C8051F9xx family not only provides high performance while saving power but also unprecedented functional density in a small footprint. The C8051F9xx is the first line of MCUs to integrate 64 kB of Flash and 4 kB of RAM into a 4 x 4 mm package while also integrating a 10-bit, 300-kps analog-to-digital converter (ADC) with an internal fast wake-up voltage reference, a smaRTClock timing module, and multiple internal oscillator options to provide a true system-on-chip solution.

LOW-VOLTAGE BLOCK DIAGRAM

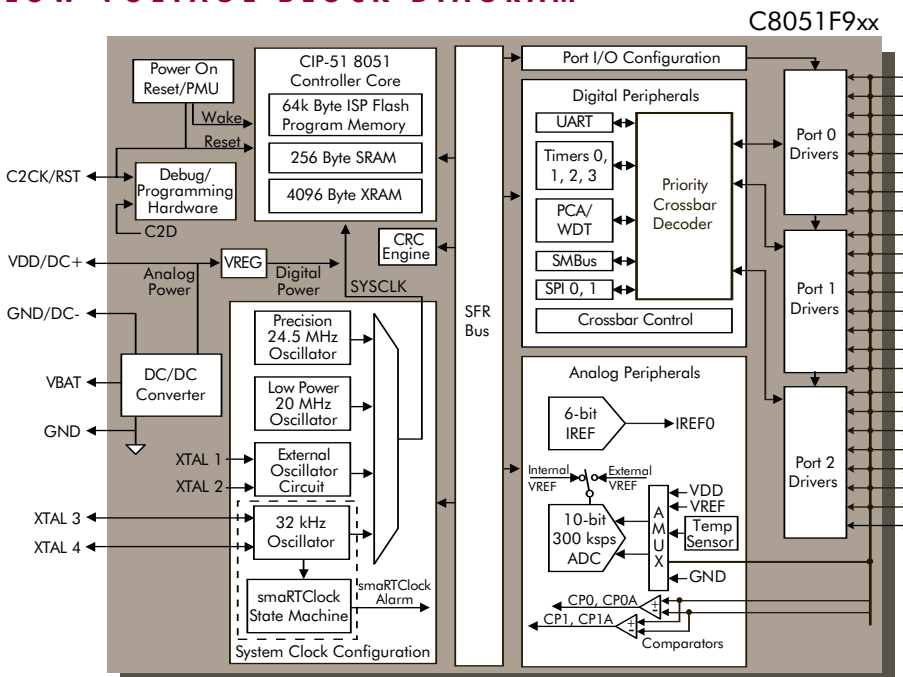

9 KEY FEATURES

- Single cell/dual-cell operation
 - One-cell mode supports 0.9 to 1.8 V operation
 - Dual-cell mode supports 1.8 to 3.6 V operation
- Integrated high-efficiency dc-dc boost converter
- Integrated low drop out (LDO) voltage regulator
- Multiple internal oscillators
 - smaRTClock oscillator
 - Low power 20 MHz oscillator
 - Precision 24.5 MHz oscillator with spread spectrum mode
- Ultra-low current sleep mode and fast wake
- 25 MHz, single-cycle 8051 compatible CPU with low active-mode current
- Unprecedented functional density
 - 64 kB Flash memory
 - 4 kB of RAM
 - 4 x 4 mm package
- Burst mode 10-bit ADC with internal fast start-up VREF
- Capacitive touch sense support
 - Two on-chip voltage comparators
 - Up to 23 capacitive touch sense inputs

APPLICATIONS

- Portable personal medical products
- Remote controls
- Portable audio
- Consumer electronics
- Wireless sensors and security
- Wireless meter reading
- Industrial monitoring and control

SOLUTIONS GUIDE

TWICE THE INNOVATION,
HALF THE BATTERIES



Low-Voltage/Low-Power Solutions

Lowest Voltage Operation

With an integrated dc-dc converter, the C8051F9xx family is the industry's first MCU capable of operating down to 0.9 V, enabling single-cell battery operation and dramatically increasing battery life for dual-cell applications, ultimately shrinking the form factor and cost of battery-powered products.

Greatest Power Efficiency

The C8051F9xx family is optimized in all operating modes to enable customers to either move to a single-cell design or increase the system's battery life by up to 2x in parallel dual-cell designs.

Highest Functional Density

With 64 kB of Flash and 4 kB of RAM in a 4 x 4 mm package, the C8051F9xx provides customers with increased memory for data-intensive applications. The small form factor makes these devices ideal for applications where end-product size is critical.

Best-in-Class Tools

Silicon Labs delivers industry-leading tools to help speed design and accelerate market entry. The complete, low-cost professional development kit includes everything required to immediately begin system design including IDE, target board, cables, and power supply. An inexpensive ToolStick Daughter Card and Base Adapter also provide a full development environment.

Low-Voltage/Low-Power Product Matrix

Part Number	Flash Memory	MIPS (peak)	RAM (bytes)	Dig I/O	Serial Buses	Timers (16-bit)	PCA Chnls	Internal Osc	ADC	Temp Sensor	VREF	Comparators	Other	Package
C8051F930	64 kB	25	4 K	24	UART, I ² C, EMIF, 2 SPI	4	6	±2%	10-bit, 23-ch., 300 ksps	Y	Y	2; up to 23 touch sense inputs	smarTClock	QFN32/LQFP32
C8051F931	64 kB	25	4 K	16	UART, I ² C, 2 SPI	4	6	±2%	10-bit, 15-ch., 300 ksps	Y	Y	2; up to 15 touch sense inputs	smarTClock	QFN24
C8051F920	32 kB	25	4 K	24	UART, I ² C, EMIF, 2 SPI	4	6	±2%	10-bit, 23-ch., 300 ksps	Y	Y	2; up to 23 touch sense inputs	smarTClock	QFN32/LQFP32
C8051F921	32 kB	25	4 K	16	UART, I ² C, 2 SPI	4	6	±2%	10-bit, 15-ch., 300 ksps	Y	Y	2; up to 15 touch sense inputs	smarTClock	QFN24

Maximize Battery Life

The C8051F9xx family is optimized to maximize power efficiency by enabling an ultra-low current sleep mode, a fast wake-up time, a fast settling time to support analog measurements, and a low active current mode, resulting in maximum battery life.

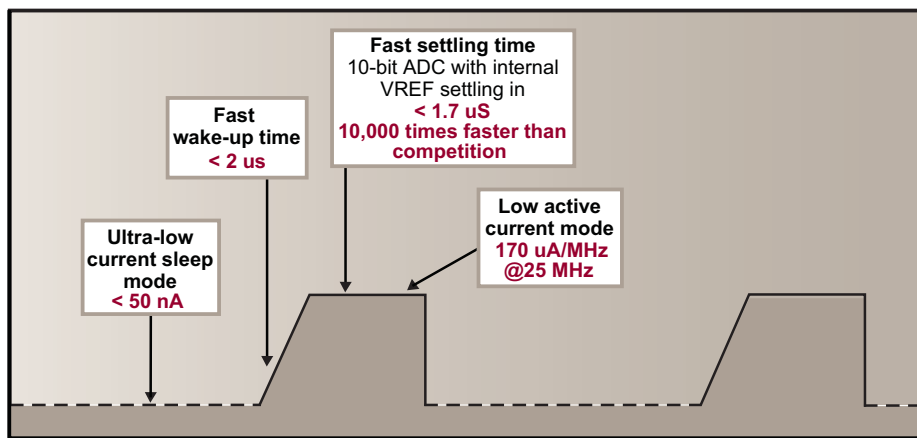

One-Cell Mode: DC-DC Converter Advantage

When the C8051F9xx is operating in single-cell mode, a high-efficiency inductor-based dc-dc converter is used to boost the battery voltage. The highly integrated converter needs only an external 0.68 µH inductor, plus decoupling capacitors on the VBAT and VDD pins. The converter's output voltage is programmable from 1.8 to 3.3 V in several discrete steps and is capable of supplying a total power of 65 mW for both internal MCU use and to drive external components such as LEDs, sensors or transceivers to create a true single-cell system solution.

DC-DC Converter Efficiency as a Function of Load Current and Battery Voltage

