

[P7] P7-CL SERIES LENS

■ Contents

1. Lens Layout
2. Lens Specification
3. Beam Pattern (Photo)
4. Feature of Beam Lens Filter
5. Lens Characteristics
6. View of the Assembly with the Collimate Lens & Beam Lens Filter
7. LED+Collimate Lens+Beam Lens Filter Assembly View & Dimensions
8. Handling of the Collimate Lens



- The P7-CL series offers low profile lens especially designed for the Seoul Semiconductor LEDs : **P7 'W724C0'**



<http://www.seoulsemicon.co.kr>

- '**P7-CL**' is ideal optical solution for P7 LEDs illumination application.

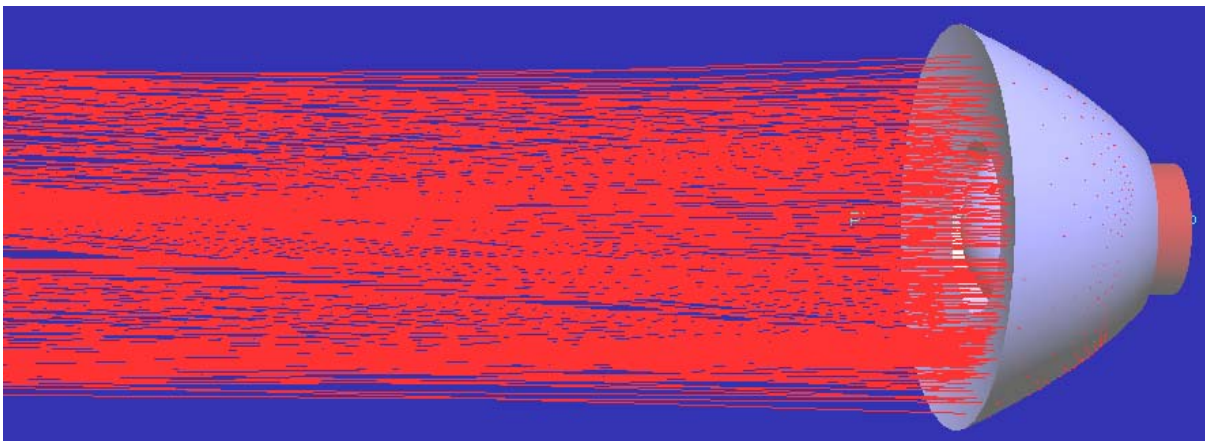

1. Lens Layout

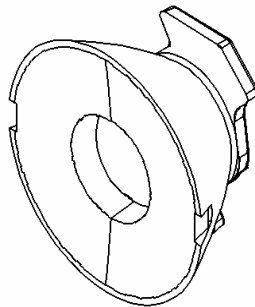

[P7-Col #1]

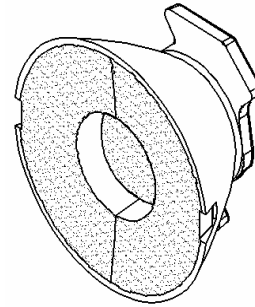

[P7-Col #2]

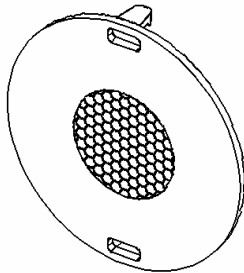

[P7-Narrow]

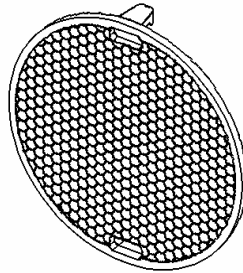

[P7-Medium]

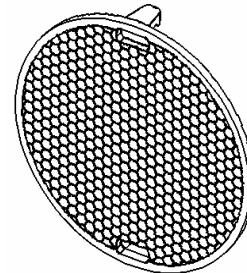

[P7-Wide]

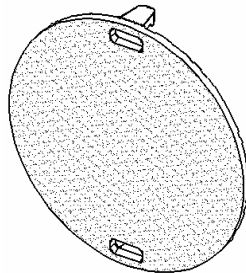

[P7-Fog]

2. Lens Specification

Lens Type	Beam Angle	Beam Pattern	Components
P7-Col #1	15 deg.	Circle	Collimate lens #1
P7-Col #2	25 deg.	Circle(Smooth)	Collimate lens #2(pattern)
P7-Narrow	15 deg.	Circle	Collimate lens + Narrow Beam Filter
P7-Medium	20 deg.	Circle	Collimate lens + Medium Beam Filter
P7-Wide	30 deg.	Circle	Collimate lens + Wide Beam Filter
P7-Fog	25 deg.	Circle(Smooth)	Collimate lens + Fog Beam Filter

3. Beam Pattern (Photo)

[Measurement Distance 100cm]

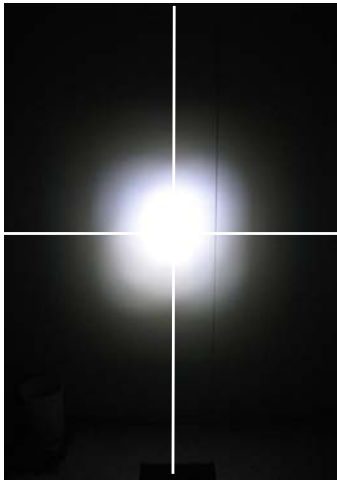

[P7-Col #1]

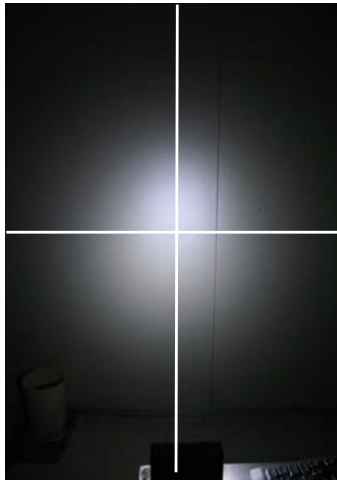

[P7-Col #2]

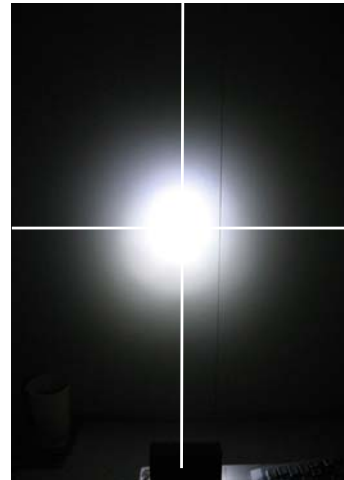

[P7-Narrow]

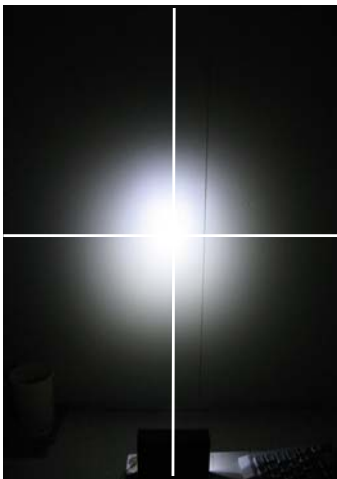

[P7-Medium]

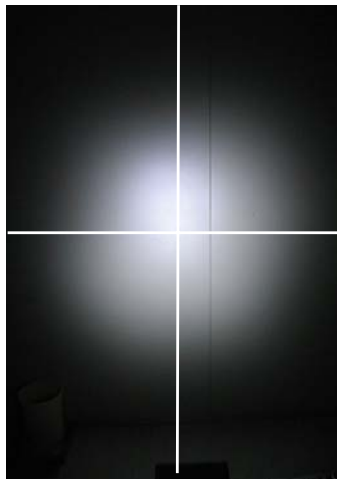

[P7-Wide]

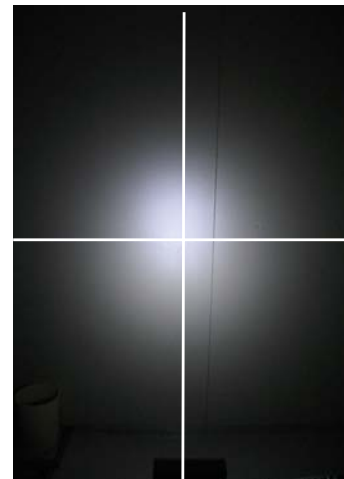

[P7-Fog]

4. Feature of Beam Lens Filter

Item	Feature
P7-Col #2	Smooth Light (no filter)
P7-Narrow	Spot Light
P7-Medium	Medium Light (Center of light is narrow)
P7-Wide	Wide Light (Center of light is wide)
P7-Fog	Smooth Light

5. Lens Characteristics

Parameter	Symbol	Value	Unit
Collimate Lens	PMMA (Optics)	-	-
Beam Lens Filter	PMMA (Optics)	-	-
Operating Temp.	T _{opr}	-40 ~ +80	°C
Storage Temp.	T _{stg}	-40 ~ +80	°C

6. View of the Assmby with the Collimate Lens & Beam Lens Filter

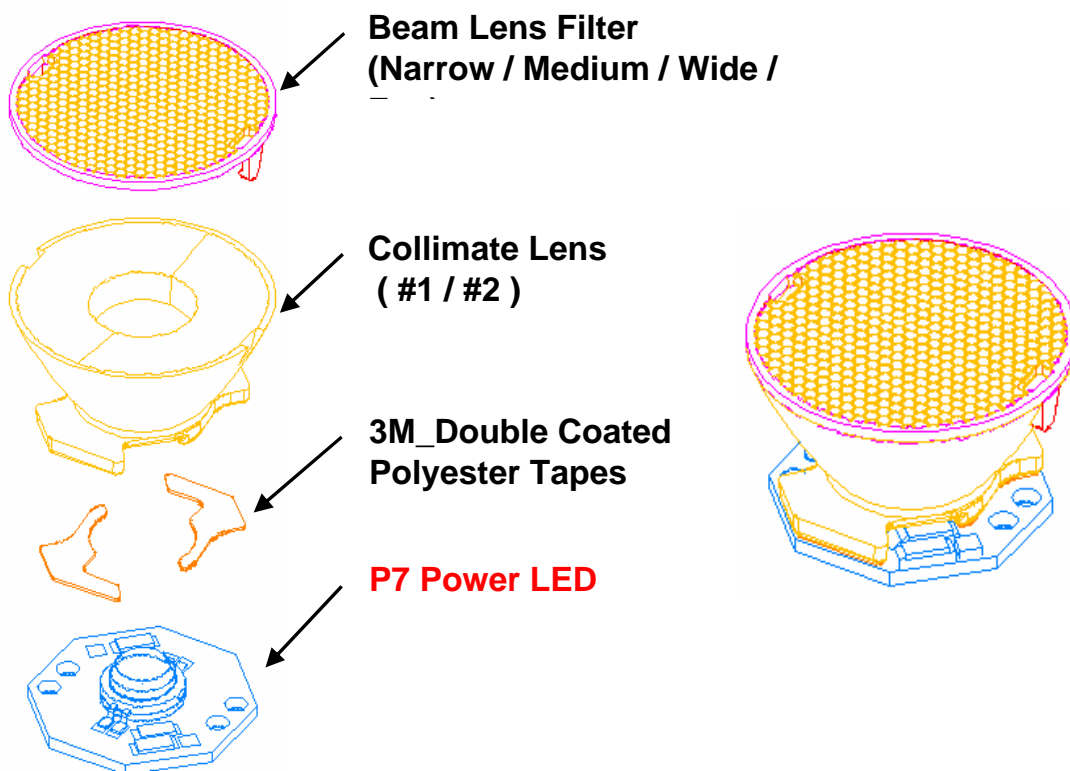

7. LED+Collimate Lens+Beam Lens Filter Assembly View & Dimensions

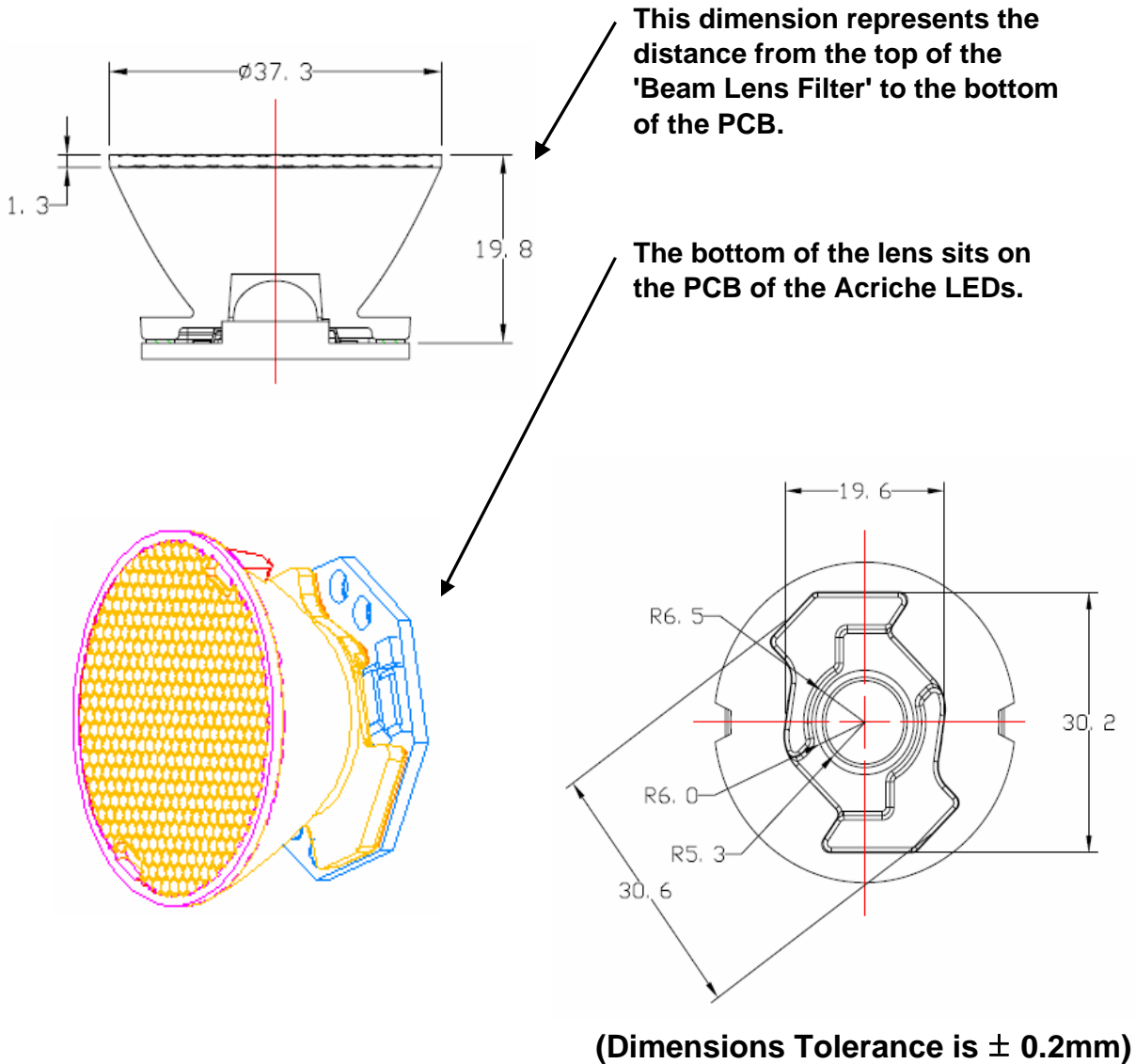

8. Handling of the Collimate Lens

- Do not store in dusty place.
- Do not expose under corrosive environment.
- Do not touch the lens surface with bare-hand.
- Do not dip in or apply to aggressive chemicals, and also.
- DO not wipe with cloth or paper soaked with aggressive chemicals.