



skillfully designed thermal circuit
breaker TA35 in 1-, 2- or 3-pole version
with illuminated or non-illuminated rocker

Thermal Circuit Breaker, rocker actuated, 1-, 2- or 3-pole

NEW



TA35 1-pole



TA35 2-pole



TA35 3-pole



Description

- Thermal circuit breaker 1-, 2- or 3-pole
- Supplementary protector for general industrial use
- Positively trip-free release
- Snap-in mounting
- Version with illuminated rocker
- Different rocker colours
- Protection cover for IP65
- «Dead-Man»-version (Momentary switch)

Standards

- IEC 60934
- UL 1077
- CSA C22.2 235
- GB 17701 (pending)

Applications

- Power tools
- Industrial equipment
- Equipment for building construction
- Medical equipment
- Cleaning equipment
- Power generators
- Commercial and household kitchen appliances

Weblinks

Approvals: <http://www.schurter.com/approvals>
 RoHS: <http://www.schurter.com/rohs>

TECHNICAL DATA

Rated voltage U_g	1-pole	AC 240 V / 50/60 Hz DC 32 V
	2-pole	AC 240 V / 50/60 Hz DC 60 V
	3-pole	AC 415 Y/240 V / 50/60 Hz
Rated current I_n	1- / 2-pole	0.05 – 20 A
	3-pole	0.05 – 12 A
Conditional short circuit I_{nc}	1- / 2-pole, AC 240 V	0.05...20 A: 2000 A, SC (C1)
	3-pole, AC 415 V	0.05...12 A: 2000 A
Degree of protection	Accessible range	IP 40
	Terminal side	IP 00
Dielectric strength	50 Hz	> 2500 V
	Impulse 1.2/50 μ s	> 4000 V
Insulation resistance	DC 500 V	> 100 M Ω m
Endurance (typical)	Mechanical	50'000 cycles
	AC: 1 x I_n , cos phi 0.6	50'000 cycles
	DC: 1 x I_n , L/R = 2...3ms	50'000 cycles

Overload	IEC 60934	min. 40 cycles @ 6 x I_n , cos phi 0.6
	UL 1077	min. 50 cycles @ 1.5 x I_n , cos phi 0.75 (OL \emptyset)
Admissible ambient air temperature		-30 °C to +60 °C
Resistance to vibration	IEC 60068-2-6, Test Tc	10...60 Hz: \pm 0.75 mm
		60...500 Hz: 10 G
Shock resistance	IEC 60068-2-27, Test Ea	30 G / 18 ms
Type of tripping		Thermal positively trip free
Weight	1-pole	19 g
	2-pole	32 g
	3-pole	45 g
Max. switching capacity for switch only types (without bimetal)	1-, 2-pole	20 A
	3-pole	12 A

TRIPPING CHARACTERISTICS

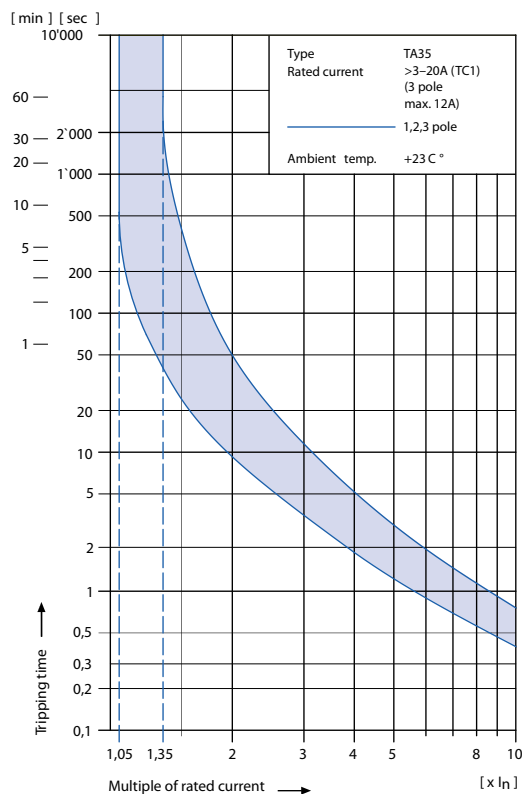
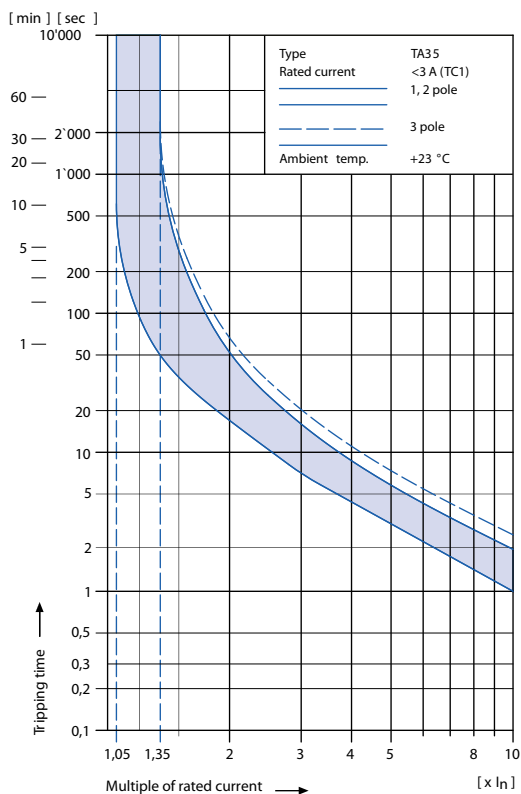

The above tripping characteristics apply to symmetrical overloads on all poles on the TA35 only.

At asymmetric overloads on multi-pole types, the tripping characteristic will change.

- If a 2-pole type TA35 is loaded at one pole only, the tripping current will be shifted by factor **1.05**.
- If a 3-pole type TA35 is loaded at one pole only, the tripping current will be shifted by factor **1.10**.

To meet the above tripping characteristic at asymmetric overloads on multi-pole types, the value of the rated current of the CBE has to be multiplied by the factor mentioned above.

Effect of ambient temperature

The unit is calibrated for an ambient temperature of +23 °C. To determine the rated current for lower or higher ambient temperature, use a correction factor from the table below.

Ambient temperature [°C]	Correction factor		
	1-pole	2-pole	3-pole
-30	0.77	0.76	0.76
-20	0.81	0.81	0.81
0	0.90	0.90	0.90
+23	1.00	1.00	1.00
+40	1.03	1.03	1.06
+50	1.04	1.04	1.10
+60	1.06	1.06	1.14

Example for 2-pole type:



Rated current at +23 °C 5.0 A
 Ambient temperature +50 °C
 Correction factor 1.04
 Chosen rated current at +40 °C
 ambient temperature: **5 A x 1.04 = 5.2 A**

Standard rated currents and typical internal resistance

Code	In	Ri [Ohm]
J01	0.1	70.000
J05	0.5	2.750
J10	1.0	0.720
J15	1.5	0.340
J20	2.0	0.187
J25	2.5	0.115
J28	2.8	0.089
030	3.0	0.059
040	4.0	0.059
050	5.0	0.044
060	6.0	0.028
070	7.0	0.0142
080	8.0	0.0142
100	10.0	0.0109
120	12.0	0.0086
140	14.0	0.0072
150	15.0	0.0056
160	16.0	0.0056
180	18.0	0.0052
200	20.0	0.0052

unprotected poles (without bimetal) 2.2 mΩ

APPROVALS

		# of poles	Rated currents	Rated voltage AC	Rated voltage DC	
	UL	UL 1077	1	0.05...20 A	240 V	32 V
			2	0.05...20 A	240 V	60 V
			3	0.05...12 A	415 Y/240 V	—
	UL	CSA C22.2 235	1	0.05...20 A	240 V	32 V
			2	0.05...20 A	240 V	60 V
			3	0.05...12 A	415 Y/240 V	—
	VDE	IEC 60934	1	0.05...20 A	240 V	32 V
			2	0.05...20 A	240 V	60 V
			3	0.05...12 A	415 Y/240 V	—
	CQC	GB 17701	1 *	0.05...20 A	240 V	32 V
			2 *	0.05...20 A	240 V	60 V
			3 *	0.05...12 A	415 Y/240 V	—

* Approvals pending

Actual information about approvals can be found on: www.schurter.com/approvals.

ORDER CODE

		1-pole		2-pole			3-pole	
Switch	without illumination	CFC	CFT	CBC	CBT	CBD	CKC	CKD
Switch	illuminated	415 V CF2	415 V C2F	240 V C02	240 V C12	240 V C32	CK1	CD1
		120 V CF4	120 V C4F	120 V C04	120 V C14	120 V C34		
		24 V CF7	24 V C7F	24 V C07	24 V C17	24 V C37		
		12 V CF8	12 V C8F	12 V C08	12 V C18	12 V C38		
		5 V CF9	5 V C9F	5 V C09	5 V C19	5 V C39		
Momentary	without illumination	CGC	CGT	CEC	CET	CED	CLC	CLD

Other versions on request



No other features

Colours

	Switch front	Rocker	
W	black	white	-
B	black	black	-
R	black	red	-
G	black	green	-
Y	black	yellow	-
X	black	orange	-
1	black	-	clear transparent
3	black	-	red transparent
4	black	-	green transparent
6	black	-	orange transparent
7	black	-	blue transparent

Other colours on request

Rocker legend

	Surface	Illustration	Colour of print
F	embossed		-
H	printed		white
K	printed		black
L	printed		white
M	printed		black

Other legends on request

Without thermal overload protection: code C00

With thermal overload protection: rated current I_n (A)

I _n	Code	I _n	Code	I _n	Code	I _n	Code
0,1	J01	1,2	J12	5,0	050	15,0	150
0,2	J02	1,5	J15	6,0	060	16,0	160
0,3	J03	2,0	J20	7,0	070	18,0	180
0,4	J04	2,5	J25	8,0	080	20,0	200
0,5	J05	3,0	030	10,0	100		
0,8	J08	3,5	035	12,0	120		
1,0	J10	4,0	040	14,0	140		

Other rated currents on request

DIMENSIONS

TA35 1-pole

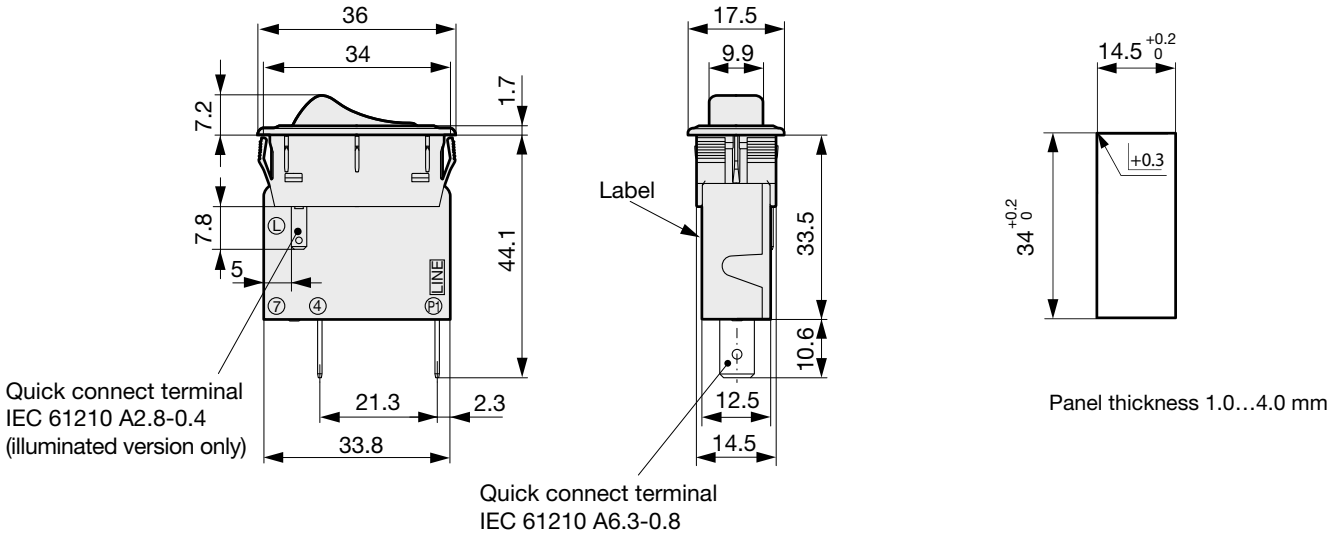

TA35 2-pole

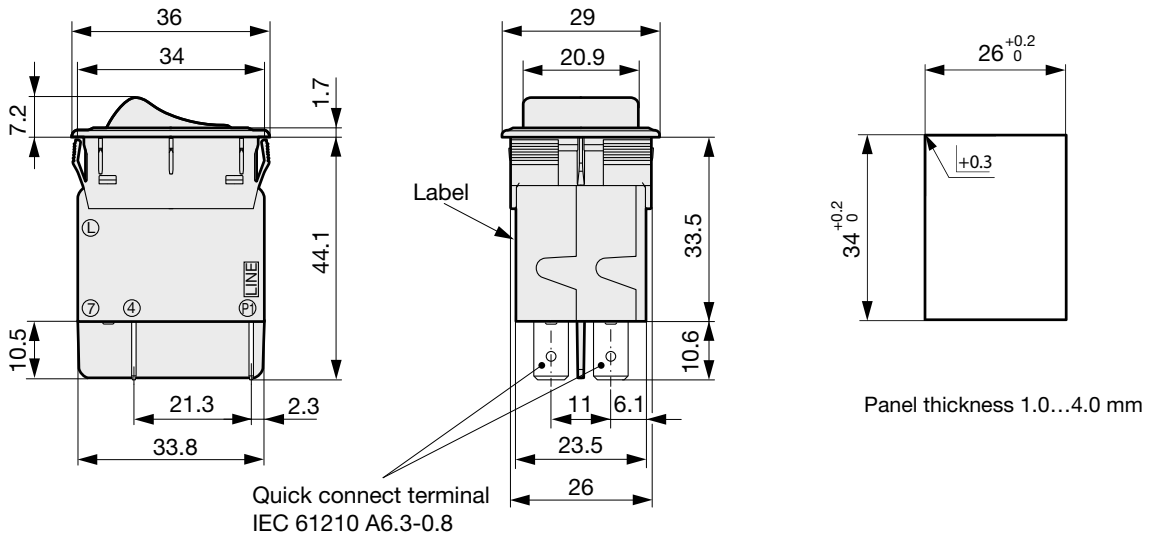

TA35 3-pole

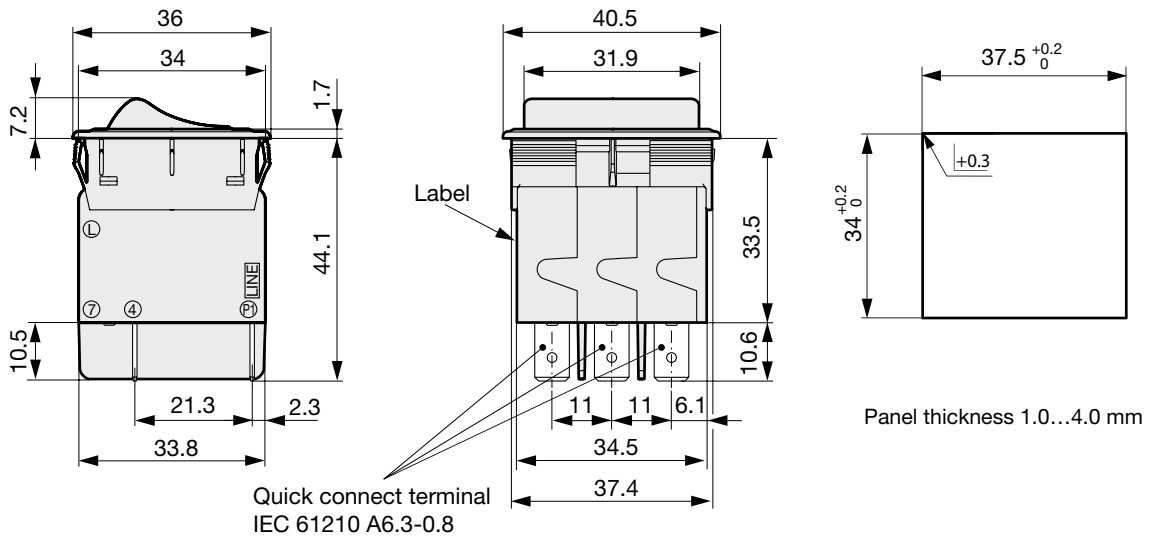

ACCESSORIES

Cover / collar for protection IP 65

CZZ11 (1-pole)

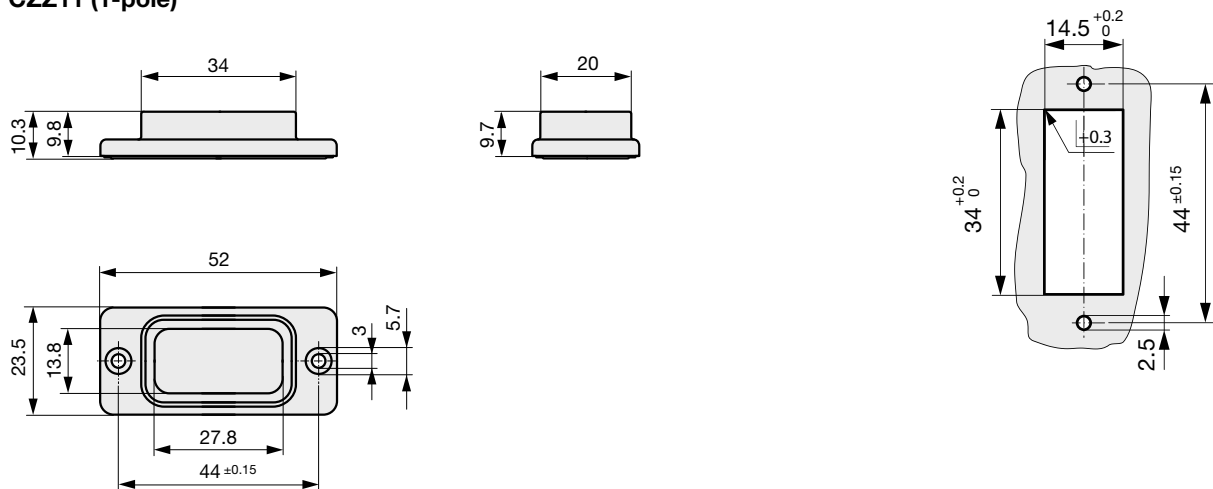

CZZ21 (2-pole)

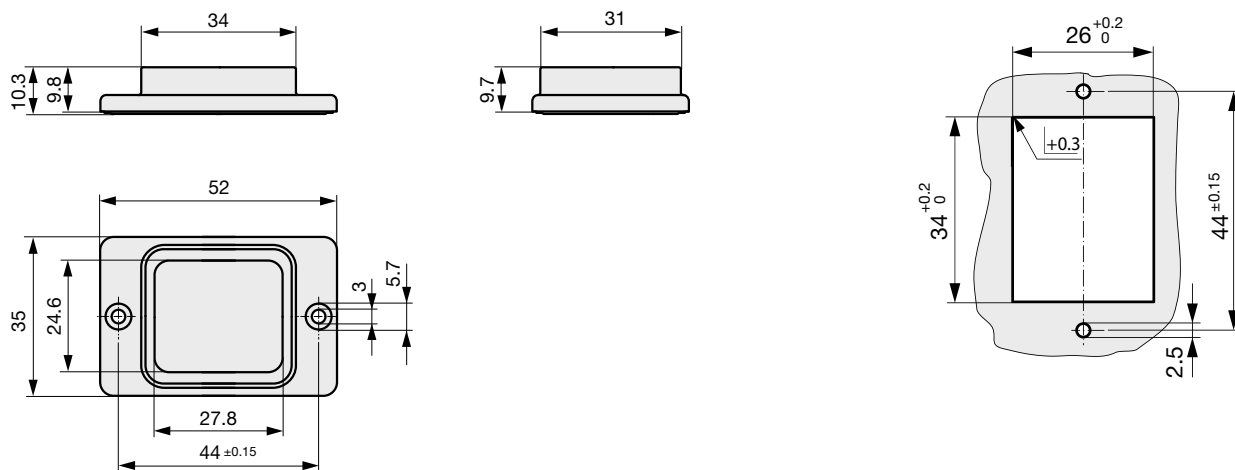

CZZ31 (3-pole)

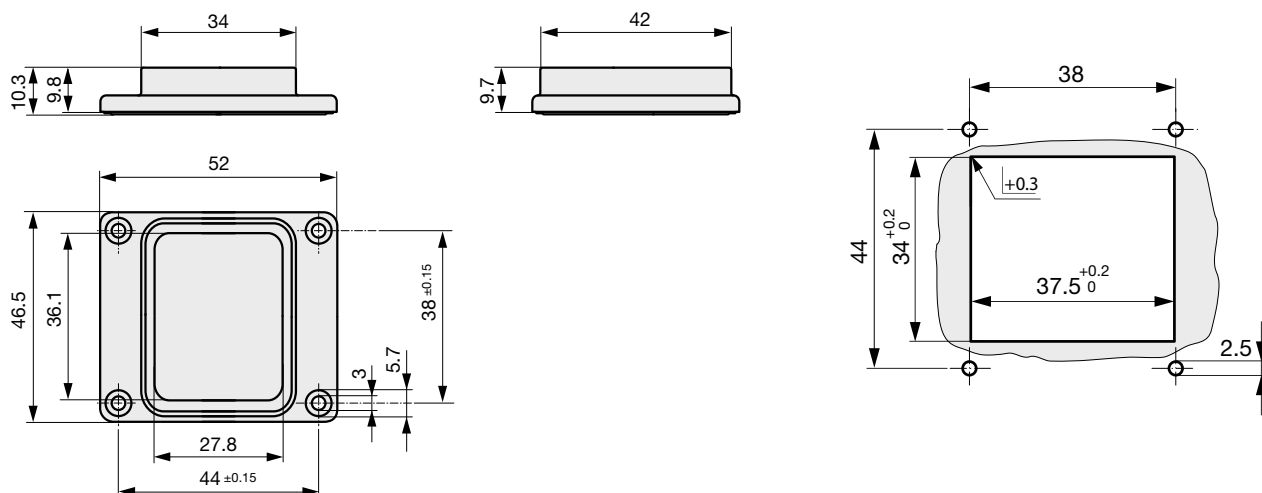

SCHURTER develops, manufactures and markets components for the electronics industries worldwide.

fuses
connectors
circuit breakers
input systems
emc-products

