

High Speed Five-Channel Digital Isolators

Functional Diagrams

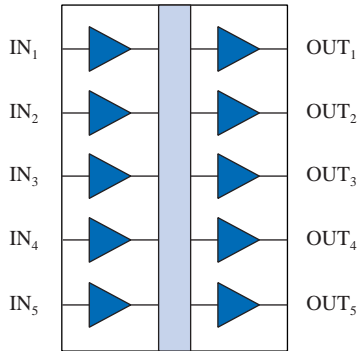

IL260

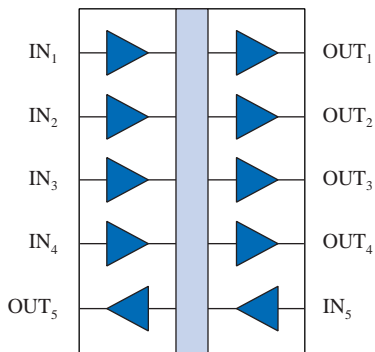

IL261

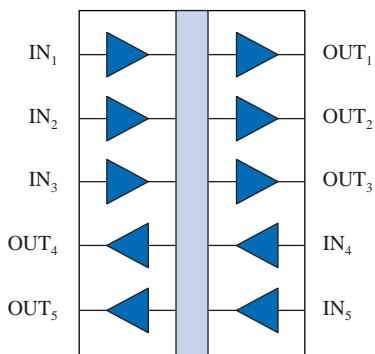

IL262

Features

- +5 V / +3.3 V CMOS/TTL Compatible
- High Speed: 110 Mbps
- Extended Temperature Range (-40°C to +85°C)
- 2500 V_{RMS} Isolation (1 min.)
- 2 ns Typical Pulse Width Distortion
- 4 ns Typical Propagation Delay Skew
- 10 ns Typical Propagation Delay
- 30 kV/μs Typical Common Mode Rejection
- 2 ns Channel-to-Channel Skew
- 0.3" and 0.15" 16-pin SOIC Packages
- UL1577 and IEC 61010-2001 Approval

Applications

- ADCs and DACs
- Multiplexed Data Transmission
- Data Interfaces
- Board-to-Board Communication
- Digital Noise Reduction
- Operator Interface
- Ground Loop Elimination
- Peripheral Interfaces
- Parallel Bus
- Logic Level Shifting
- Plasma Displays

Description

NVE's IL260-Series five-channel high-speed digital isolators are CMOS devices manufactured with NVE's patented* IsoLoop[®] spintronic Giant Magnetoresistive (GMR) technology.

All transmit and receive channels operate at 110 Mbps over the full temperature and supply voltage range. The symmetric magnetic coupling barrier provides a typical propagation delay of only 10 ns and a pulse width distortion of 2 ns, achieving the best specifications of any isolator. The unique fifth channel can be used to distribute isolated clocks or handshake signals to multiple delta-sigma A/D converters. High channel density makes these devices ideal for isolating ADCs and DACs, parallel buses and peripheral interfaces.

Typical transient immunity of 30 kV/μs is unsurpassed. Performance is specified over the temperature range of -40°C to +85°C without derating.

IL260-Series Isolators are available in 0.3" and 0.15" 16-pin SOIC packages. In the 0.15" packages, the five-channel devices provide the highest channel density available.

Absolute Maximum Ratings

Parameters	Symbol	Min.	Typ.	Max.	Units	Test Conditions
Storage Temperature	T_S	-55		150	°C	
Ambient Operating Temperature ⁽¹⁾	T_A	-55		125	°C	
Supply Voltage	V_{DD1}, V_{DD2}	-0.5		7	V	
Input Voltage	V_I	-0.5		$V_{DD} + 0.5$	V	
Output Voltage	V_O	-0.5		$V_{DD} + 0.5$	V	
Output Current Drive	I_O	-10		10	mA	
Lead Solder Temperature				260	°C	10 sec.
ESD			2		kV	HBM

Recommended Operating Conditions

Parameters	Symbol	Min.	Typ.	Max.	Units	Test Conditions
Ambient Operating Temperature	T_A	-40		85	°C	
Supply Voltage	V_{DD1}, V_{DD2}	3.0		5.5	V	3.3/5.0 V Operation
Logic High Input Voltage	V_{IH}	2.4		V_{DD}	V	
Logic Low Input Voltage	V_{IL}	0		0.8	V	
Input Signal Rise and Fall Times	t_{IR}, t_{IF}			1	µs	

Insulation Specifications

Parameters	Symbol	Min.	Typ.	Max.	Units	Test Conditions
Creepage Distance (external)						
0.15" SOIC		4.03			mm	
0.3" SOIC		8.08			mm	
Leakage Current ⁽⁵⁾			0.2		µA _{RMS}	240 V _{RMS}
Barrier Impedance ⁽⁵⁾			$>10^{14} 7$		Ω pF	
Capacitance (Input-Output) ⁽⁵⁾	C_{I-O}		5		pF	f = 1 MHz

Safety and Approvals

IEC61010-2001

TUV Certificate Numbers: N1502812, N1502812-101

Classification as Reinforced Insulation

Model	Package	Pollution Degree	Material Group	Max. Working Voltage
IL260, IL261, IL262	0.3" 16-pin SOIC	II	III	300 V _{RMS}
IL260-3, IL261-3, IL262-3	0.15" 16-pin SOIC	II	III	150 V _{RMS}

UL 1577

Component Recognition Program File Number: E207481
Rated 2500 V_{RMS} for 1 minute (SOIC, PDIP)

Soldering Profile

Per JEDEC J-STD-020C, MSL=2

Electrostatic Discharge Sensitivity

This product has been tested for electrostatic sensitivity to the limits stated in the specifications. However, NVE recommends that all integrated circuits be handled with appropriate care to avoid damage. Damage caused by inappropriate handling or storage could range from performance degradation to complete failure.

IL260 Pin Connections

1	IN ₁	Input 1
2	GND ₁	Ground
3	IN ₂	Input 2
4	IN ₃	Input 3
5	IN ₄	Input 4
6	V _{DD1}	Supply Voltage 1
7	IN ₅	Input 5
8	GND ₁	Ground
9	GND ₂	Ground
10	OUT ₅	Output 5
11	OUT ₄	Output 4
12	OUT ₃	Output 3
13	OUT ₂	Output 2
14	OUT ₁	Output 1
15	GND ₂	Ground
16	V _{DD2}	Supply Voltage 2

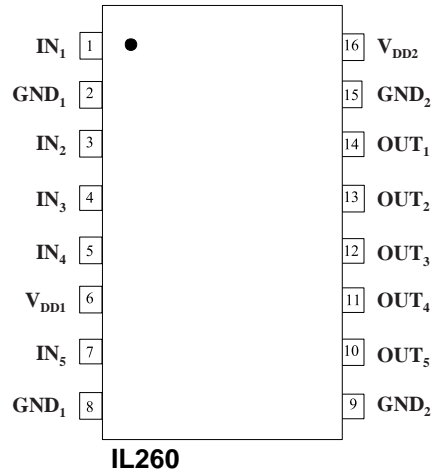

IL261 Pin Connections

1	V _{DD1}	Supply Voltage 1
2	GND ₁	Ground
3	IN ₁	Input 1
4	IN ₂	Input 2
5	IN ₃	Input 3
6	IN ₄	Input 4
7	OUT ₅	Output 5
8	GND ₁	Ground
9	GND ₂	Ground
10	IN ₅	Input 5
11	OUT ₄	Output 4
12	OUT ₃	Output 3
13	OUT ₂	Output 2
14	OUT ₁	Output 1
15	GND ₂	Ground
16	V _{DD2}	Supply Voltage 2

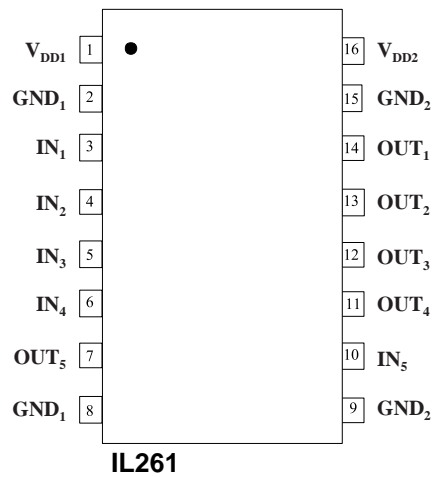

IL262 Pin Connections

1	V _{DD1}	Supply Voltage 1
2	GND ₁	Ground
3	IN ₁	Input 1
4	IN ₂	Input 2
5	IN ₃	Input 3
6	OUT ₄	Output 4
7	OUT ₅	Output 5
8	GND ₁	Ground
9	GND ₂	Ground
10	IN ₅	Input 5
11	IN ₄	Input 4
12	OUT ₃	Output 3
13	OUT ₂	Output 2
14	OUT ₁	Output 1
15	GND ₂	Ground
16	V _{DD2}	Supply Voltage 2

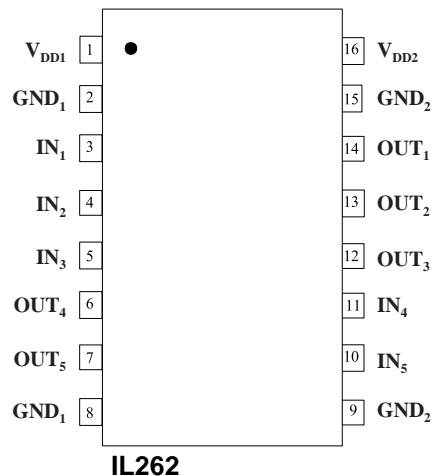

3.3 Volt Electrical Specifications (T_{min} to T_{max})

Parameters	Symbol	Min.	Typ.	Max.	Units	Test Conditions
Input Quiescent Current	IL260	I _{DD1}	30	50	μA	
	IL261		1.5	2	mA	
	IL262		3	4	mA	
Output Quiescent Current	IL260	I _{DD2}	6.5	10	mA	
	IL261		5	8	mA	
	IL262		3.5	6	mA	
Logic Input Current	I _I	-10		10	μA	
Logic High Output Voltage	V _{OH}	V _{DD} -0.1	V _{DD}		V	I _O = -20 μA, V _I =V _{IH}
		0.8 x V _{DD}	0.9 x V _{DD}			I _O = -4 mA, V _I =V _{IH}
Logic Low Output Voltage	V _{OL}		0	0.1	V	I _O = 20 μA, V _I =V _{IL}
			0.5	0.8		I _O = 4 mA, V _I =V _{IL}
Switching Specifications						
Maximum Data Rate		100	110		Mbps	C _L = 15 pF
Minimum Pulse Width	PW	10			ns	50% Points, V _O
Propagation Delay Input to Output (High to Low)	t _{PHL}		12	18	ns	C _L = 15 pF
Propagation Delay Input to Output (Low to High)	t _{PLH}		12	18	ns	C _L = 15 pF
Pulse Width Distortion t _{PHL} -t _{PLH} ⁽²⁾	PWD		2	3	ns	C _L = 15 pF
Propagation Delay Skew ⁽³⁾	t _{PSK}		4	6	ns	C _L = 15 pF
Output Rise Time (10%-90%)	t _R		2	4	ns	C _L = 15 pF
Output Fall Time (10%-90%)	t _F		2	4	ns	C _L = 15 pF
Common Mode Transient Immunity (Output Logic High to Logic Low) ⁽⁴⁾	CM _H , CM _L	20	30		kV/μs	V _{CN} = 300 V
Channel to Channel Skew			2	3	ns	C _L = 15 pF
Dynamic Power Consumption ⁽⁶⁾			140	240	μA/MHz	per channel

5 Volt Electrical Specifications (T_{min} to T_{max})

Parameters	Symbol	Min.	Typ.	Max.	Units	Test Conditions
Input Quiescent Current	IL260	I _{DD1}	30	50	μA	
	IL261		2.5	3	mA	
	IL262		5	6	mA	
Output Quiescent Current	IL260	I _{DD2}	10	15	mA	
	IL261		7.5	12	mA	
	IL262		5	9	mA	
Logic Input Current	I _I	-10		10	μA	
Logic High Output Voltage	V _{OH}	V _{DD} -0.1	V _{DD}		V	I _O = -20 μA, V _I =V _{IH}
		0.8 x V _{DD}	0.9 x V _{DD}			I _O = -4 mA, V _I =V _{IH}
Logic Low Output Voltage	V _{OL}		0	0.1	V	I _O = 20 μA, V _I =V _{IL}
			0.5	0.8		I _O = 4 mA, V _I =V _{IL}
Switching Specifications						
Maximum Data Rate		100	110		Mbps	C _L = 15 pF
Minimum Pulse Width ⁽⁷⁾	PW	10			ns	50% Points, V _O
Propagations Delay Input to Output (High to Low)	t _{PHL}		10	15	ns	C _L = 15 pF
Propagations Delay Input to Output (Low to High)	t _{PLH}		10	15	ns	C _L = 15 pF
Pulse Width Distortion t _{PHL} -t _{PLH} ⁽²⁾	PWD		2	3	ns	C _L = 15 pF
Propagation Delay Skew ⁽³⁾	t _{PSK}		4	6	ns	C _L = 15 pF
Output Rise Time (10%-90%)	t _R		1	3	ns	C _L = 15 pF
Output Fall Time (10%-90%)	t _F		1	3	ns	C _L = 15 pF
Common Mode Transient Immunity (Output Logic High to Logic Low)	CM _H , CM _L	20	30		kV/μs	V _{CN} = 300 V
Channel-to-Channel Skew			2	3	ns	C _L = 15 pF
Dynamic Power Consumption ⁽⁶⁾			200	340	μA/MHz	per channel

Notes (apply to both 3.3 V and 5 V specifications):

1. Absolute maximum ambient operating temperature means the device will not be damaged if operated under these conditions. It does not guarantee performance.
2. PWD is defined as $|t_{\text{PHL}} - t_{\text{PLH}}|$. %PWD is equal to PWD divided by pulse width.
3. t_{PSK} is the magnitude of the worst-case difference in t_{PHL} and/or t_{PLH} between devices at 25°C.
4. CM_{H} is the maximum common mode voltage slew rate that can be sustained while maintaining $V_{\text{o}} > 0.8 V_{\text{DD2}}$. CM_{L} is the maximum common mode input voltage that can be sustained while maintaining $V_{\text{o}} < 0.8 \text{ V}$. The common mode voltage slew rates apply to both rising and falling common mode voltage edges.
5. Device is considered a two terminal device: pins 1–8 shorted and pins 9–16 shorted.
6. Dynamic power consumption numbers are calculated per channel and are supplied by the channel's input side power supply.
7. Minimum pulse width is the minimum value at which specified PWD is guaranteed.

Application Information

Dynamic Power Consumption

IsoLoop Isolators achieve their low power consumption from the way they transmit data across the isolation barrier. By detecting the edge transitions of the input logic signal and converting these to narrow current pulses, a magnetic field is created around the GMR Wheatstone bridge. Depending on the direction of the magnetic field, the bridge causes the output comparator to switch following the input logic signal. Since the current pulses are narrow, about 2.5 ns, the power consumption is independent of mark-to-space ratio and solely dependent on frequency. This has obvious advantages over optocouplers, which have power consumption heavily dependent on mark-to-space ratio.

Power Supply Decoupling

Both power supplies to these devices should be decoupled with low ESR 47 nF ceramic capacitors. Ground planes for both GND₁ and GND₂ are highly recommended for data rates above 10 Mbps. Capacitors must be located as close as possible to the V_{DD} pins.

Signal Status on Start-up and Shut Down

To minimize power dissipation, input signals are differentiated and then latched on the output side of the isolation barrier to reconstruct the signal. This could result in an ambiguous output state depending on power up, shutdown and power loss sequencing. Therefore, the designer should consider including an initialization signal in the start-up circuit. Initialization consists of toggling the input either high then low, or low then high.

Data Transmission Rates

The reliability of a transmission system is directly related to the accuracy and quality of the transmitted digital information. For a digital system, those parameters which determine the limits of the data transmission are pulse width distortion and propagation delay skew.

Propagation delay is the time taken for the signal to travel through the device. This is usually different when sending a low-to-high than when sending a high-to-low signal. This difference, or error, is called pulse width distortion (PWD) and is usually in nanoseconds. It may also be expressed as a percentage:

$$\text{PWD\%} = \frac{\text{Maximum Pulse Width Distortion (ns)}}{\text{Signal Pulse Width (ns)}} \times 100\%$$

For example, with data rates of 12.5 Mbps:

$$\text{PWD\%} = \frac{3 \text{ ns}}{80 \text{ ns}} \times 100\% = 3.75\%$$

This figure is almost **three times** better than any available optocoupler with the same temperature range, and **two times** better than any optocoupler regardless of published temperature range. IsoLoop isolators exceed the 10% maximum PWD recommended by PROFIBUS, and will run to nearly 35 Mb within the 10% limit.

Propagation delay skew is the signal propagation difference between two or more channels. This becomes significant in clocked systems because it is undesirable for the clock pulse to arrive before the data has settled. Short propagation delay skew is therefore especially critical in high data rate parallel systems for establishing and maintaining accuracy and repeatability. Worst-case channel-to-channel skew in IL260-Series Isolators is only 3 ns, which is **ten times** better than any optocoupler. IL260-Series Isolators have a maximum propagation delay skew of 6 ns, which is **five times** better than any optocoupler.

Application Diagram—Multi-Channel Delta-Sigma A/D Converter

In a typical single-channel delta-sigma ADC, the system clock is located on the isolated side of the system and only four channels of isolation are required. With multiple ADCs configured in a channel-to-channel isolation configuration, however, clock jitter and edge placement accuracy of the system clock must be matched between ADCs. The best solution is to use a single clock on the system side and distribute the clock to each ADC. The five-channel IL261 is ideal, with the fifth channel used to distribute a single, isolated clock to multiple ADCs as shown below:

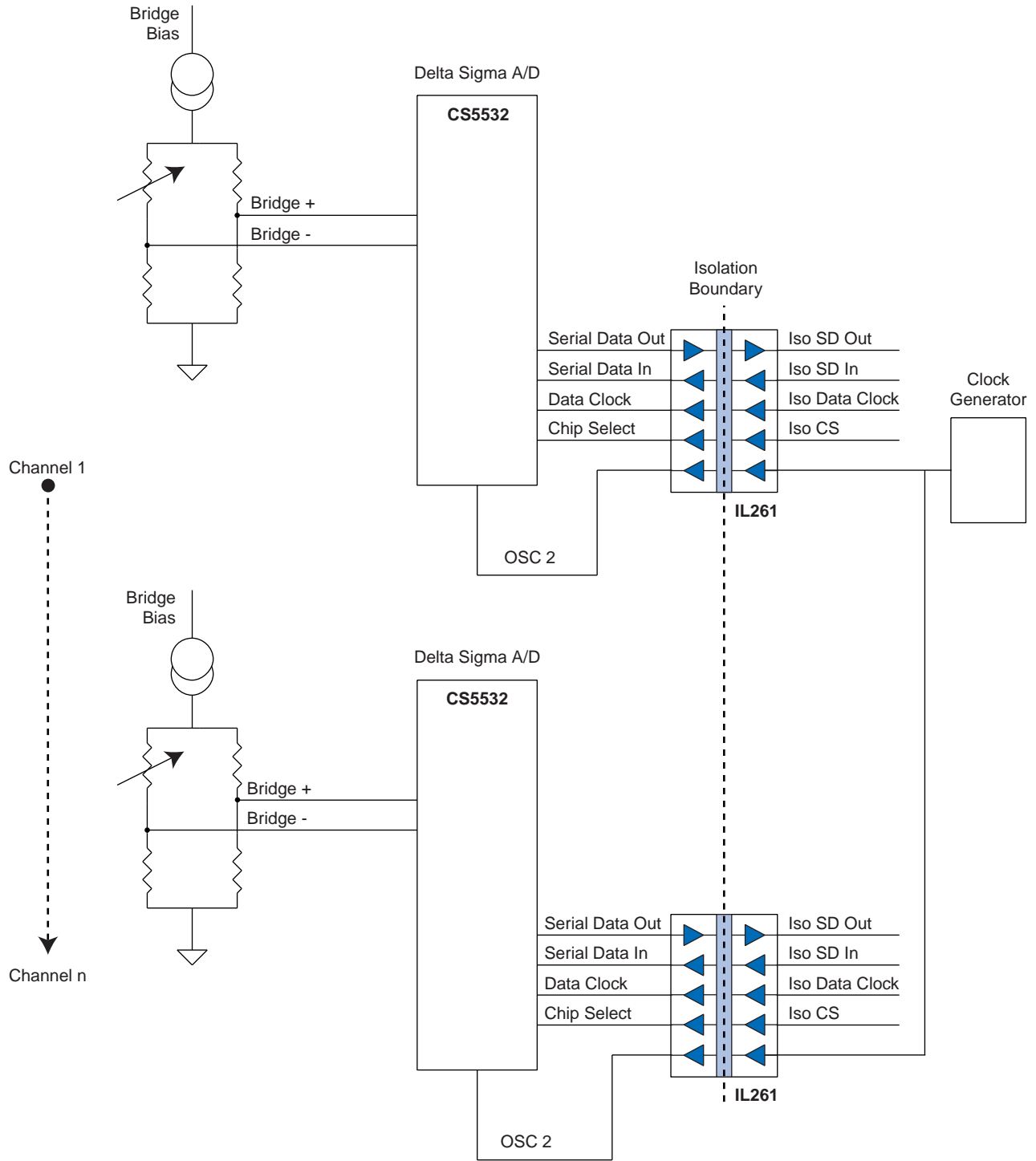

Package Drawings, Dimensions and Specifications

0.15" 16-pin SOIC Package

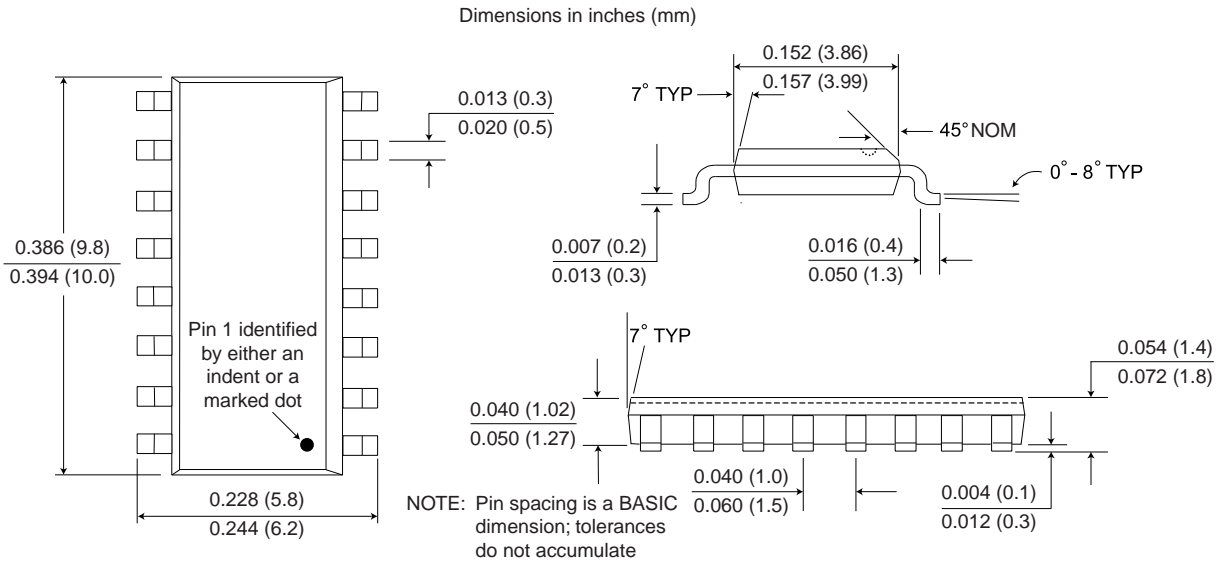

0.3" 16-pin SOIC Package

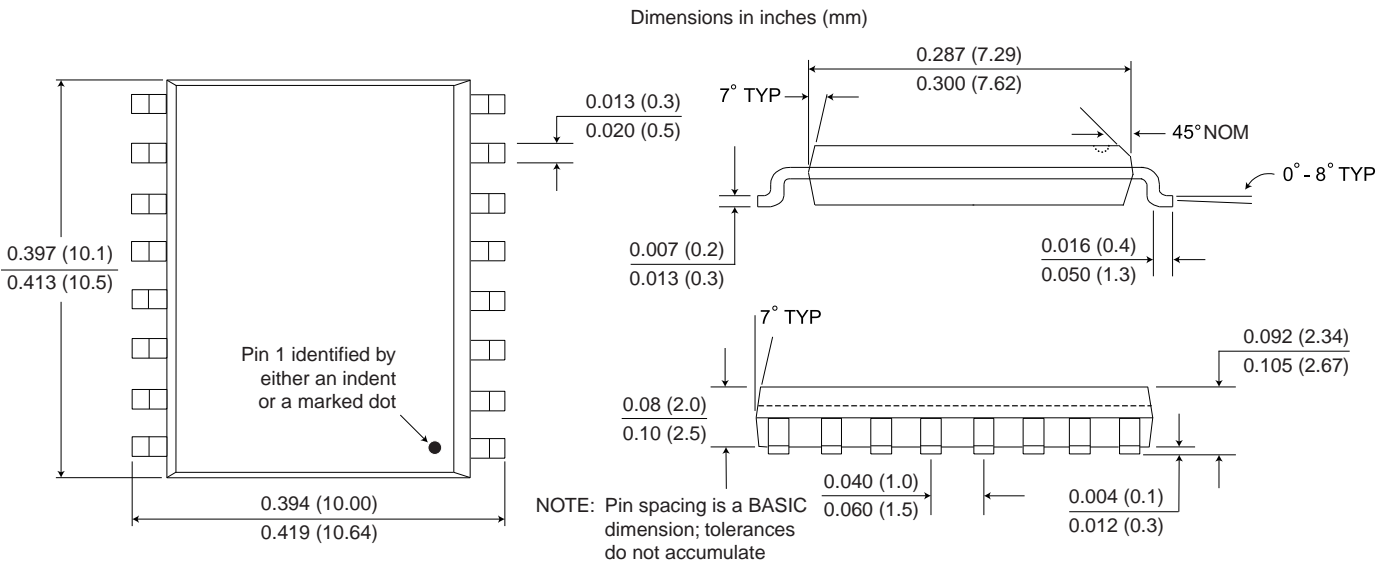

Ordering Information and Valid Part Numbers

IL 260 - 3 E TR13

Valid Part Numbers

IL260
IL260E
IL260-3
IL260-3E
IL261
IL261E
IL261-3
IL261-3E
IL262
IL262E
IL262-3
IL262-3E

All IL260-Series part types are available on tape and reel.

Bulk Package

Blank = Tube
TR7 = 7" Tape and Reel
TR13 = 13" Tape and Reel

Package

Blank = 80/20 Tin/Lead Plating
E = RoHS Compliant

Package Type

Blank = 0.3" 16-pin SOIC
-3 = 0.15" 16-pin SOIC

Base Part Number

260 = 5 Drive Channels
261 = 4 Drive Channels,
1 Receive Channel
262 = 3 Drive Channels,
2 Receive Channel

Product Family

IL = Isolators

RoHS
COMPLIANT

Revision History

ISB-DS-001-IL260/1/2-F February 2008

Change

- Added IL262 configuration
- Added note on package drawings that pin-spacing tolerances are non-accumulating.
- Changed ordering information to reflect that devices are fully RoHS compliant with no exemptions.

ISB-DS-001-IL260/1-E

Change

- Eliminated soldering profile chart

ISB-DS-001-IL260/1-D

Change

- Revised application drawing
- Revised package drawings
- Misc. syntax changes

ISB-DS-001-IL260/1-C

Change

Page 2: UL File Number and TUV Certificate Numbers added

Page 9: Soldering Profile added.

ISB-DS-001-IL260/1-B

Change

Page 1: Revision letter added
Old ISB number removed

Page 2: Storage temperature changed from 175°C max to 150°C max.

Page 2: Lead soldering temperature changed from 280°C max to 260°C max.

Page 2: Absolute Maximum Ratings: Ambient Operation Note ⁽¹⁾ added.

Page 2: Recommended Operating Conditions: Ambient Operation Note ⁽¹⁾ removed.

Page 2: IEC 61010-1 Classification “as Table 1 Reinforced Insulation” added.

Page 9: Ordering Information. 5 volt only option removed.

Valid Part Numbers IL260 B, IL260BE, IL260BETR13, IL260BTR13, IL260-3B, IL260-3BE, IL260-3BTR7, IL260-3BTR13, IL260-3BETR7, IL260-3BETR13, IL261B IL261BE, IL261BETR13, IL261BTR13, IL261-3B, IL261-3BE, IL261-3BTR7, IL261-3BTR13, IL261-3BETR7, and IL261-3BETR13 removed.

About NVE

An ISO 9001 Certified Company

NVE Corporation is a high technology components manufacturer having the unique capability to combine spintronic Giant Magnetoresistive (GMR) materials with integrated circuits to make high performance electronic components. Products include Magnetic Field Sensors, Magnetic Field Gradient Sensors (Gradiometer), Digital Magnetic Field Sensors, Digital Signal Isolators and Isolated Bus Transceivers.

NVE is a leader in GMR research and in 1994 introduced the world's first products using GMR material, a line of GMR magnetic field sensors that can be used for position, magnetic media, wheel speed and current sensing.

NVE is located in Eden Prairie, Minnesota, a suburb of Minneapolis. Please visit our Web site at www.nve.com or call (952) 829-9217 for information on products, sales or distribution.

NVE Corporation
11409 Valley View Road
Eden Prairie, MN 55344-3617 USA
Telephone: (952) 829-9217
Fax: (952) 829-9189
Internet: www.nve.com
e-mail: isoinfo@nve.com

The information provided by NVE Corporation is believed to be accurate. However, no responsibility is assumed by NVE Corporation for its use, nor for any infringement of patents, nor rights or licenses granted to third parties, which may result from its use. No license is granted by implication, or otherwise, under any patent or patent rights of NVE Corporation. NVE Corporation does not authorize, nor warrant, any NVE Corporation product for use in life support devices or systems or other critical applications without the express written approval of the President of NVE Corporation.

Specifications shown are subject to change without notice.

ISB-DS-001-IL260/1/2-F

February 2008